

# Skid unit with a centrifugal pump

Tankless  
Low pressure

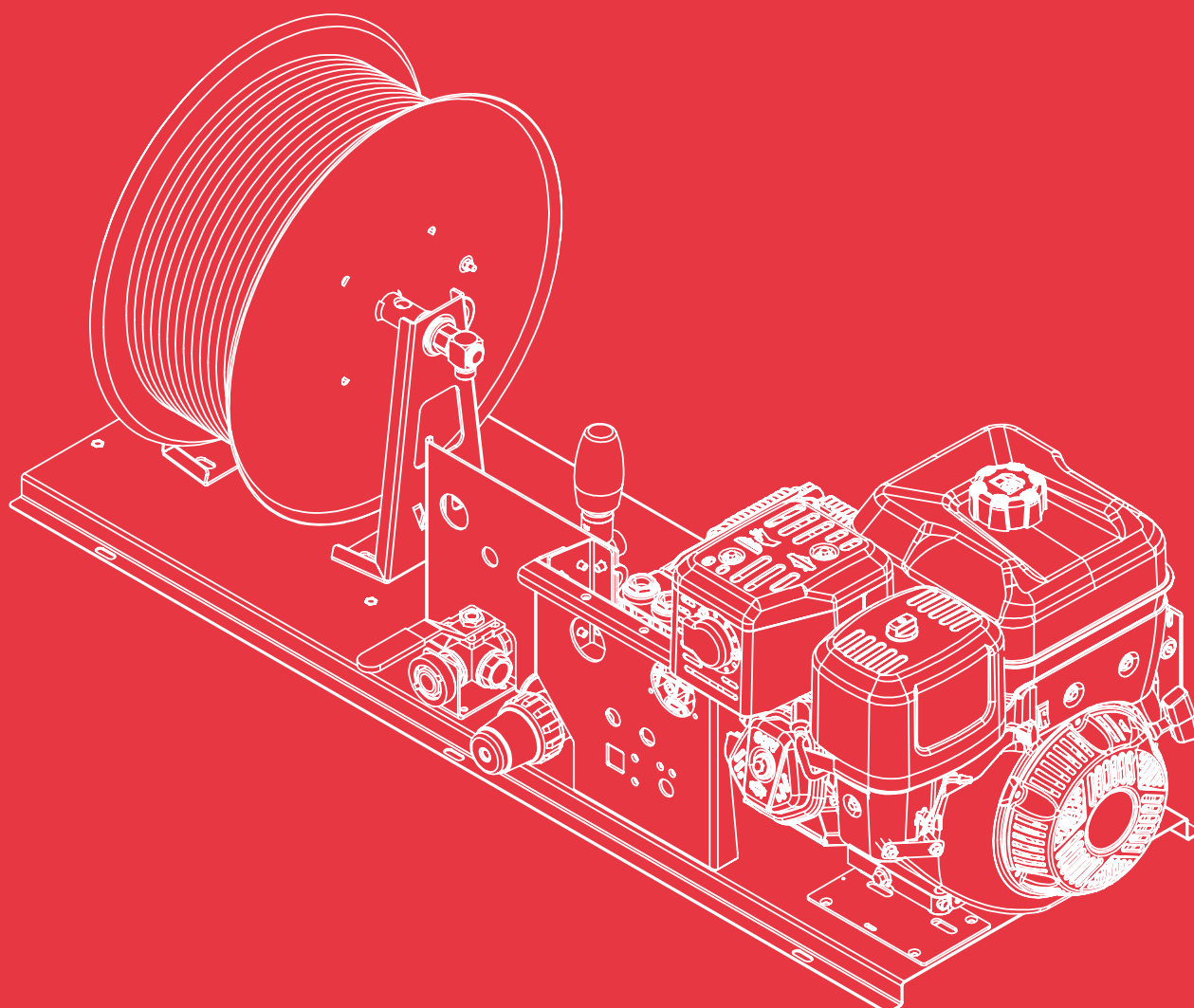

# Skid unit with a centrifugal pump

Low pressure | Up to 25 bar

Rapid intervention extinguishing module designed to be connected to any adapted tank and transported on pickup vehicles and trailers, 100% customizable. Equipped with centrifugal pumps up to 25 bar with a maximum flow of up to 390 L/min.

- High-quality components and great replacement part availability
- The best quality/price ratio
- 2 year warranty

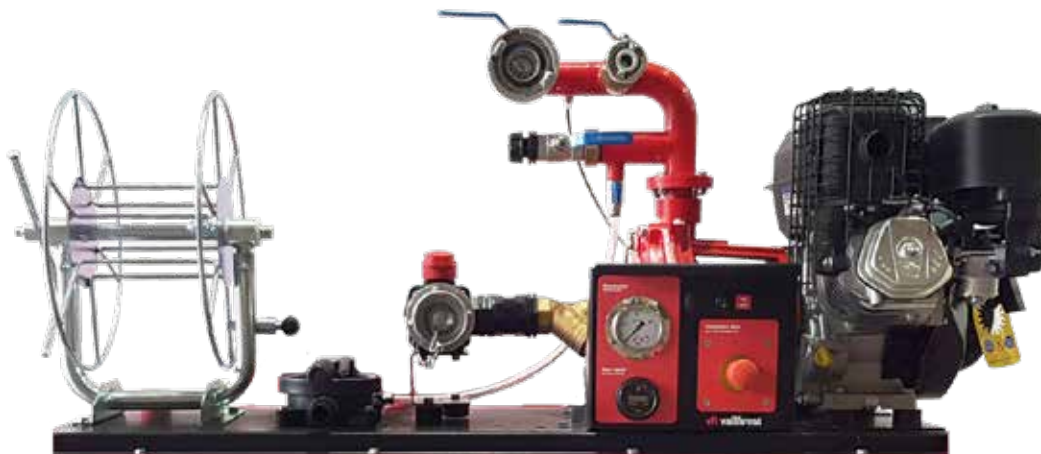

## What is included?

<b>Motor</b>	<b>Gasoline</b> ( 6.5 - 13.5 HP)
<b>Centrifugal pump</b>	From 260 L/min.   6.9 bar to 390 L/min.   25 bar
<b>Quick attack winder</b>	Mounted on the main structure
<b>Suction oversleeve</b>	5 m long

## Uses

<b>Wildland fires</b>	Recommended use
<b>Container and vehicle fires</b>	Recommended use
<b>Cleaning and unclogging</b>	Not recommended

# 1 Motor pump unit

Available options. 4-stroke gasoline motors and low-pressure centrifugal pumps.



Motor	Power*	Pump	Max. pressure**	Max. flow**
Honda GXH50	2.1 HP	VFT_1SP4	6.9 bar	260 l/min
B&S XR1450	10 HP	2RD 50/9	12 bar	258 l/min
B&S XR2100	13.5 HP	2RD 50/13	15.5 bar	275 l/min
Honda GX390	11.7 HP	VFT_4SP	25 bar	390 l/min
B&S XR2100	13.5 HP	VFT_4SP	25 bar	390 l/min

Gasoline motor.

\* The nominal engine power indicated in this document is the net power tested on a production engine for the engine model pursuant to SAE J1349 (HONDA) / SAE J1940 (Briggs& Stratton) at a specific speed. This value may vary in mass produced motors. The actual output power of the engine installed on the end machine will vary depending on a number of factors such as the applicable engine operating speed, the environmental conditions, maintenance and other variables.

\*\* These values are at direct pump outlet.

\*\*\* The power, pressure and flow values are valid in working conditions: temperature 25°C at sea level. **IMPORTANT:** Engine power will decrease 3.5% for every 300 meters above sea level and 1% for each 5.6°C above 25°C.



**HONDA**



## 2 Components included

### 2.1 Control panel

Control panel with LED light switch, pressure gauge time counter and skid unit emergency stop.\*

#### TECHNICAL DATA

- Baked paint coating.
- \* Skid units without batteries do not have light, nor time counter.
- \* DVD0900-BH1A0 skid unit only has a pressure gauge.



### 2.2 Winder

Made of anti-corrosive material with a manual starting crank and lock system.

#### TECHNICAL DATA

- Capacity for 40 m flat 25 hose\*
- \* Option available: winder with capacity for 20 m semi-rigid DN25 hose (already included in DVD0900-BH1A0 skid unit)



### 2.3 Suction oversleeve

Clear flexible PVC spiral absorption oversleeve with rigid PVC spiral and smooth inner surface. Includes non-return foot valve and filter. Includes a Storz connector for connection to the Vallfirest skid unit.

#### TECHNICAL DATA

- Length: 5 m
- Oversleeve diameter: DN40 (1-1/2") or DN50 (2") depending on the pump
- Weight: 4 kg (DN40) or 5.5 kg (DN50)



## 3 Optional accessories

### 3.1 Water nozzle

vft SG540 wildland nozzle with four adjustable flow rates. Compatible with proportioners. Good performance in extreme conditions, easy maintenance, resistant and long-lasting. Additional bleed-cleaning position.

#### TECHNICAL DATA

- Maximum pressure: 30 bar
- Adjustable flow 19/37/90/150 L/min.
- Weight: 1.25 kg
- Coupling: Barcelona / Storz / DSP / NH



### 3.2 Foam nozzle

Viper Foam 1560 low-expansion foam nozzle made of light aluminum. Anodized surface for greater durability. Rotating inlet easily adaptable to any connector.

#### TECHNICAL DATA

- Maximum pressure: 7 bar
- Maximum flow: 133 L/min.
- Coupling: Barcelona / Storz / DSP / NH



### 3.3 Thermoplastic nozzle tip

Highly robust thermoplastic nozzle tip - ideal for wildland use. Turning the nozzle tip shuts off the flow of water or changes the type of stream.

#### TECHNICAL DATA

- Direct close, solid stream and self-protection stream effects
- Fixed teeth
- Fixed flow
- 7 bar maximum pressure
- Reach: 22 m
- Weight: 300 g
- Coupling: Barcelona / Storz / DSP / NH / 1 1/2" BSP fixed thread



### 3.4 Hoses

#### DN25 semi-rigid

Three-layer hose for low-pressure systems. Made of high-tenacity circularly woven 100% synthetic thread, completely protected and encapsulated with a mix of PVC and high-resistance synthetic nitrile rubber extruded through the fabric to form a single homogeneous structure without glue or adhesives.

#### TECHNICAL DATA

- Maximum pressure: 20 bar
- Standard length: 20 and 50 m bands
- Nominal diameter: 25 mm



#### 3-layer flat

Three-layer hose for use under low pressure in two 20 m bands made of circular woven fabric, 100% high-tenacity thread, completely protected by a layer of synthetic rubber to create a homogeneous structure.

#### TECHNICAL DATA

- 40 bar maximum pressure
- 25 or 45 mm hose section
- Available with Storz, Barcelona, DSP or NH connector



### 3.5 Foam-forming agent proportioner system

Compact and easy-to-use, foam mixing with a proportional manual selector valve. Creates a stable mix of foam-forming agent in the water. "Through the pump" system in which the water and foam-forming agent mix circulates through the pump body.

### 3.6 100 m Manual winder

Made of anti-corrosive material with a manual starting crank and lock system.

#### TECHNICAL DATA

- Capacity for 80 m flat 25 hose

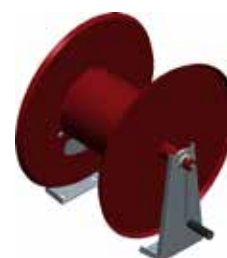

## 4 General dimensions

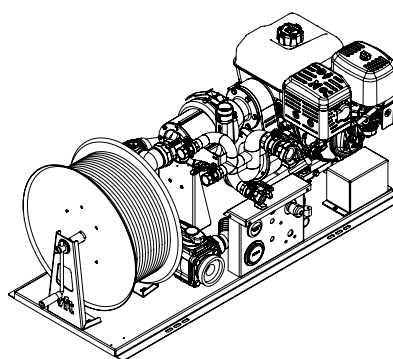
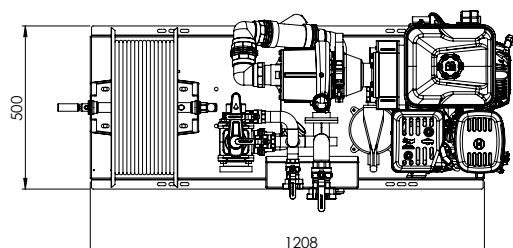
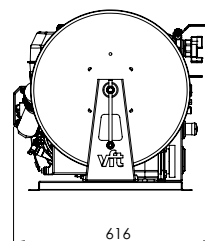
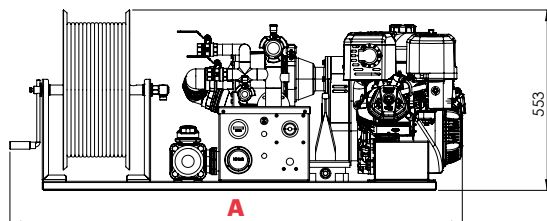

## 5 Available configurations

Ref. VFT	Tank	Motor	Battery and electric start	Power *	Pump	** Max. pressure	** Max. flow	Approx dry weight	A [mm]
DVD0900-BH1A0	450 VD	Honda GXH50	NO	2.1 HP	VFT_1SP4	6.9 bar	260 l/min		1130
DVD0900-G04A0	450 VD	B&S XR1450	YES	10 HP	2RD 50/9	12 bar	258 l/min		1350
DVD0900-G07A0	450 VD	B&S XR2100	YES	13.5 HP	2RD 50/13	15.5 bar	275 l/min		1350
DVD0900-BH4A0	450 VD	Honda GX390	YES	11.7 HP	VFT_4SP	25 bar	390 l/min		1385
DVD0900-BH4A2	450 VD	B&S XR2100	YES	13.5 HP	VFT_4SP	25 bar	390 l/min		1385

Gasoline motor.

\* The nominal engine power indicated in this document is the net power tested on a production engine for the engine model pursuant to SAE J1349 (HONDA) / SAE J1940 (Briggs & Stratton) at a specific speed. This value may vary in mass produced motors. The actual output power of the engine installed on the end machine will vary depending on a number of factors such as the applicable engine operating speed, the environmental conditions, maintenance and other variables.

\*\* These values are at direct pump outlet.

\*\*\* The power, pressure and flow values are valid in working conditions: temperature 25°C at sea level. **IMPORTANT:** Engine power will decrease 3.5% for every 300 meters above sea level and 1% for each 5.6°C above 25°C.

Any questions? Contact us: [clientes@vallfirest.com](mailto:clientes@vallfirest.com) | T. +34 938 678 779